

Power Topology Considerations for Electric Vehicle Charging Stations



Harish Ramakrishnan, Jayanth Rangaraju

ABSTRACT

As the number of electric vehicles (EVs) increase, there is a growing need to create more energy-efficient charging infrastructure systems around the world that can charge vehicles faster than ever before. New EVs have higher ranges and larger battery capacities than their predecessors, necessitating the development of fast DC charging solutions to support quick charging requirements. In this Application Report we look into topology consideration for designing power modules that acts as a building block for design of these fast DC Charging Station.

Table of Contents

1 Introduction	2
1.1 AC Charging Station.....	2
1.2 DC Charging Station.....	3
2 Power Module in DC Charging Station	3
2.1 Power Stage in a Fast DC Charger.....	4
2.2 AC/DC and DC/DC Power Stages.....	5
3 Power Topologies in AC/DC (PFC)	6
3.1 Single-phase Totem Pole PFC.....	6
3.2 Single-phase Neutral Point Clamped PFC.....	7
3.3 Three-phase Two-level PFC.....	8
3.4 Three-phase Vienna PFC.....	8
3.5 Three-phase ANPC/NPC Three-level PFC.....	10
3.6 Three-phase TNPC Three-level PFC.....	11
3.7 Summary of AC/DC Topologies.....	13
4 Power Topologies in DC/DC	14
4.1 Conventional Phase-shifted Full Bridge (PSFB).....	14
4.2 Dual Active Bridge (DAB).....	15
4.3 LLC Resonant Converter.....	16
4.4 DAB in CLLLC Mode.....	17
4.5 Summary of DC/DC Topologies.....	18
5 Upcoming Trends in DC Fast Charging Infrastructure	19
5.1 Portable Chargers.....	19
5.2 Vehicle-to-Grid Technology (V2G).....	20
6 Conclusion	20
7 References	21

Trademarks

All trademarks are the property of their respective owners.

1 Introduction

A charging station is part of the grid infrastructure installed along a street, parking lot or in a home garage; its primary purpose is to supply the power to the PHEV for charging the battery. There are mainly two types of charging systems, as shown in Table 1-1: AC and DC charging systems.

An AC charger powers the EV battery through the vehicle's on-board charger, while a DC charger directly charges the vehicle's battery.

Table 1-1 details the charging stations classified based on power levels.

Table 1-1. Charging Station Classification

EVSE Type	Power Supply	Charger Power	Charging Time* (approximate) for a 24-kWh Battery
AC charging station: L1 residential	120/230 V _{AC} and 12 A to 16 A (Single Phase)	Approximately 1.44 kW to approximately 1.92 kW	Approximately 17 Hours
AC charging station: L2 commercial	208–240 V _{AC} and 15 A to approximately 80 A (Single/split phase)	Approximately 3.1 kW to approximately 19.2 kW	Approximately 8 Hours
DC charging station: L3 fast chargers	300 to 600 V _{DC} and (Max 400 A) (Poly phase)	From 120 kW up to 240 kW	Approximately 30 Minutes

1.1 AC Charging Station

A Level 1 EVSE uses commonly-available 120 V_{AC}/230 V_{AC} power sources, draws current in the order of a 12 A to 16 A range and can take anywhere from 12 to 17 hours to fully charge a 24-kWh battery. L1 chargers can go up to a maximum power of 2 kW and is used in residential applications. A Level 2 EVSE (typically used in commercial spaces such as malls, offices, and so forth) uses poly-phase 240 V_{AC} sources to power a more robust vehicle charger and draws anywhere between 15 A and 80 A to completely charge a 24-kWh battery in about eight hours (power level up to 20 kW). Figure 1-1 shows a typical block diagram of an AC charging station.

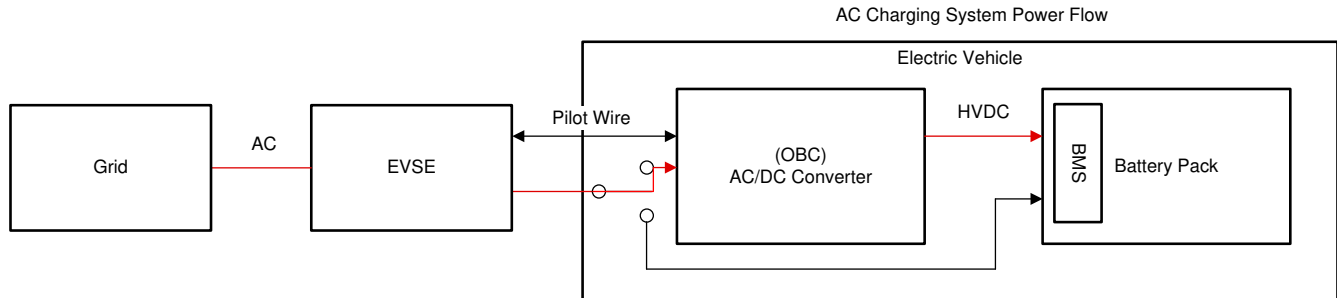

Figure 1-1. AC Charging Station

1.2 DC Charging Station

The DC charging station is a Level 3 charger which can cater for very high power level in the range of 120 to 240 kW. The L3 chargers typically charge batteries to 80% State of Charge (SOC) in under 30 minutes. To achieve such high power levels modular converters which can be stacked are used. Stacking of converters inside the vehicle makes the vehicle bulky. Hence, these stacked converters are placed outside the vehicle and constitute the EV charging station. The EV charging station is directly interfaced with the battery of the vehicle bypassing the onboard charger. Figure 1-2 shows a typical block diagram of a DC charging station.

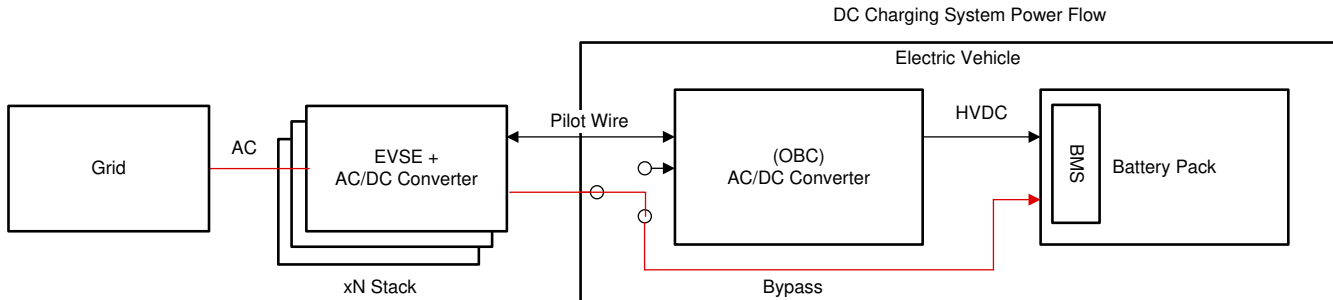

Figure 1-2. DC Charging Station

For more information on on-board chargers and off-board chargers, see the [Taking charge of electric vehicles – both in the vehicle and on the grid white paper](#) .

2 Power Module in DC Charging Station

The power module in a DC charging station consists of AC/DC power stage and DC/DC power stage integrated into the charging station. Each converter is associated with its power stage comprises of power switches and gate driver, current and voltage sensing, and controller. Each of EV charging station power module subsystems are described in detail in the upcoming sections.

2.1 Power Stage in a Fast DC Charger

Figure 2-1 shows the system level block diagram of a EV charging station power module captured from TI's *EV charging station power module*, web page. On the input side it has three-phase AC mains which are connected to the AC/DC power stage. This block converts the incoming AC voltage into a fixed DC voltage of around 800 V. This voltage serves as input to the DC/DC power stage which processes power and interfaces directly with the battery on the electric vehicle.

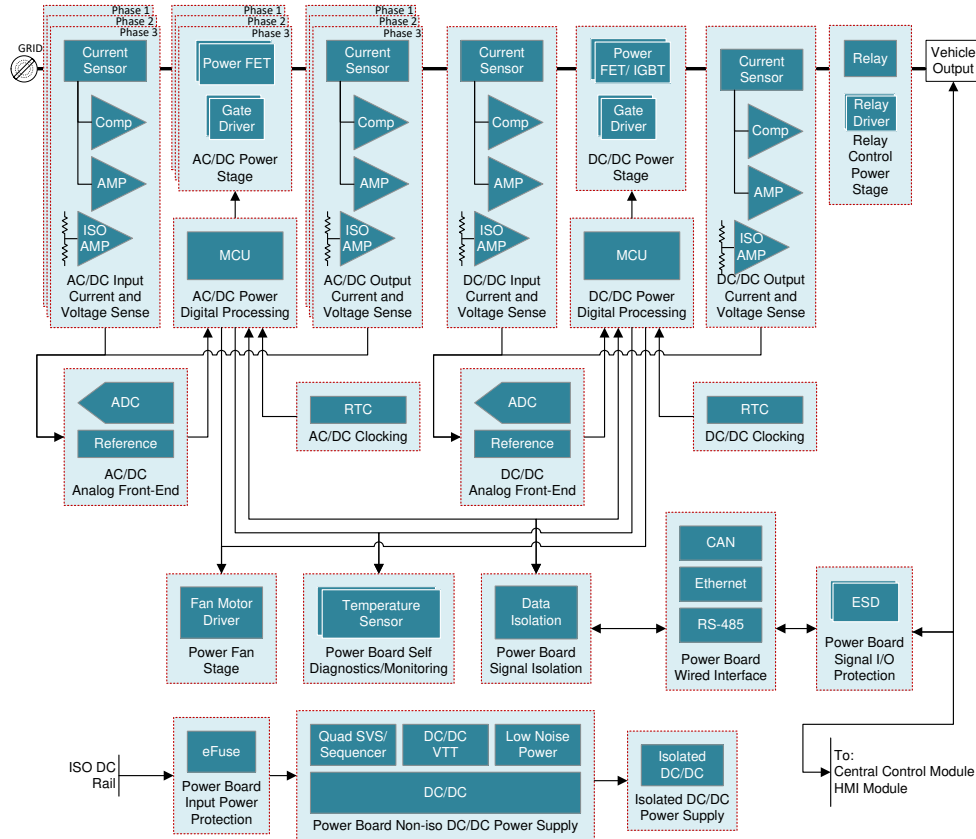

Figure 2-1. EERD of EV Charging Station Power Module

The gate drivers driving the power stage MOSFETs also form part of the power stage. In addition to the power stage, current and voltage sensing blocks are available at the input and output of both stages. This is primarily used for control, monitoring, and protection purposes. Each power stage has a separate controller which is responsible for the processing of analog signals and providing fast control action. Apart from this, there are different blocks for temperature sensing, interface for CAN, Ethernet, and RS-485, and isolated and non-isolated DC/DC converters powering the auxiliary circuits like fans for cooling the heat sinks, isolated amplifiers, and so forth. The focus on the remainder of this application report is on the choice of topology for the AC/DC and DC/DC power conversion stage.

2.2 AC/DC and DC/DC Power Stages

DC charging stations require high-power converters which are capable of charging to 80% SOC in under 30 minutes. These fast charging applications require modular power converters which can be paralleled to cater to different power levels, thereby enabling fast charging. The most important parameters are the energy density and system efficiency. Energy density is the amount of energy that can be transferred for a given volume of converter. If we can double the power output for the same size, it results in significant cost savings and also helps in fast charging. This is accomplished by operating the converter at high switching frequencies which reduces the size of magnetics and thereby helps achieve high power density. A higher system efficiency means lower losses and a smaller heat sink solution for a given application. It also reduces the thermal stress on devices and contributes to longer life expectancy of parts. The latest trend in automotive technology is the concept of Vehicle to Grid (V2G) which allows for the flow of energy from the battery to the grid for stability of grid when the vehicle is parked or not in use. This requires both the power stages to be bidirectional for supporting such applications. The converter must also be capable of providing galvanic isolation between the input and output stage through a high-frequency transformer with the required voltage conversion ratio as per the application. The converter must operate at high efficiency through inherent soft switching (like ZVS/ZCS) over a wide input and output voltage range.

The AC/DC stage (also known as the PFC stage) is the first level of power conversion in an EV charging station. It converts the incoming AC power from the grid (380–415 V_{AC}) into a stable DC link voltage of around 800 V. As shown before, the PFC stage is very important to maintain sinusoidal input currents, with typically a THD < 5%, to provide controlled DC output voltage higher than the amplitude of the line-to-line input voltage, single-stage power conversion, no galvanic isolation, unidirectional and bidirectional power flow possibly with (limited) capability of reactive power compensation, simple circuit topology, simple modulation and control scheme, and the possibility to achieve high efficiency and high power density.

The DC/DC stage is the second level of power conversion in an EV charging station. It converts the incoming DC link voltage of 800 V (in case of three-phase systems) to a lower DC voltage to charge the battery of an electric vehicle. The electric vehicle charging standards are governed by standards such as Combined Charging System (CCS) and CHAdeMO. The DC/DC converter must be capable of delivering rated power to the battery over a wide range, for example 50V-500V to accommodate batteries from 48V (e-bikes) all the way up to 400V (PHEV) with the capability of charging the battery at constant current and at constant voltage mode, depending on the State Of Charge (SOC) of the battery.

3 Power Topologies in AC/DC (PFC)

The individual topologies are classified into passive, hybrid, and active PFC rectifier systems. With the recent advancements in semiconductor technology, active PFCs are widely used in EV charging stations. Depending on the power level, both single-phase as well as three-phase topologies are used in EV charging stations. Single-phase topologies are typically used for power levels less than 3.3 kW and three-phase topologies are used at much higher power levels. In this application report single-phase PFC topologies namely totem pole, interleaved totem pole and Neutral Point Clamped topology are briefly introduced and then we mainly focus on three-phase PFC topologies; namely the two-level PFC, Vienna PFC, Neutral Point Clamped (NPC) 3 level PFC and T-type NPC PFC.

3.1 Single-phase Totem Pole PFC

Figure 3-1 shows the totem pole PFC topology which is a conventional boost PFC where one half of the diode bridge is replaced by active switches S1 and S2 in a half bridge configuration, hence the name “totem pole”. The diode S3 and S4 forms the slow 50- to 60-Hz line frequency leg which can either be slow AC rectifier diodes or can be replaced by low- $R_{DS(on)}$ synchronous MOSFETs for improved efficiency.

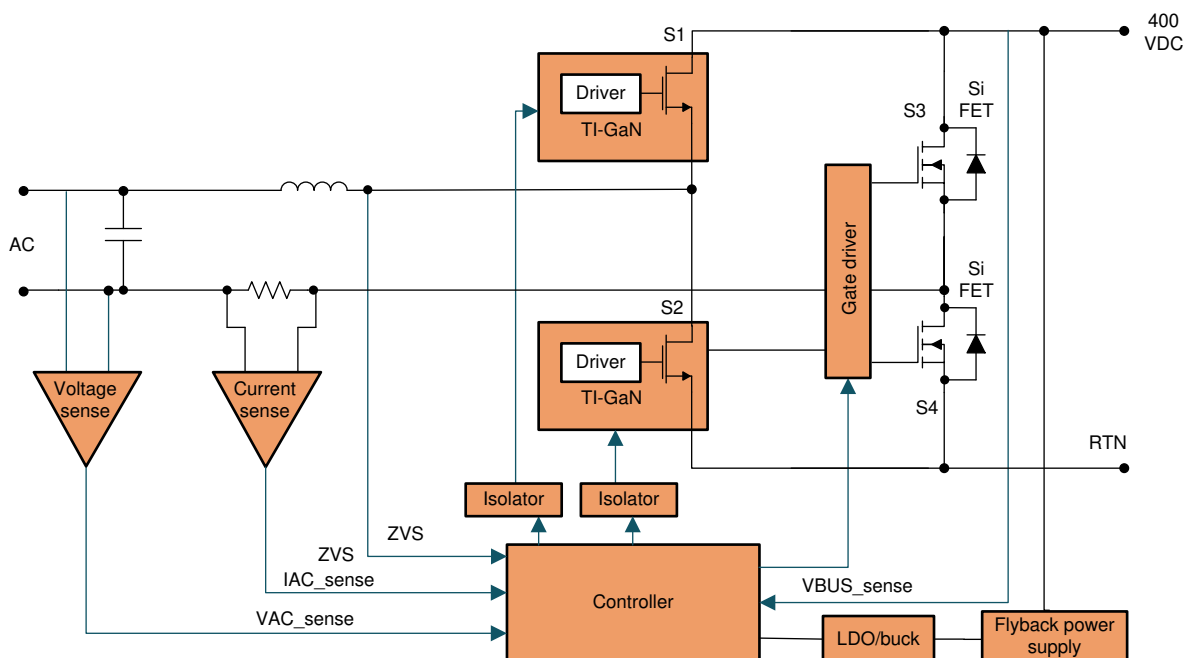

Figure 3-1. Totem Pole PFC

The totem pole PFC has the advantages of improved efficiency. The main current only flows through two switches at a time. S1 and S2 are driven synchronously with complimentary PWM signals and the S3/S4 on the slow line frequency legs can be diodes or low $R_{ds(on)}$ Si MOSFETs to further reduce the conduction loss. Secondly, with lower part counts, it offers higher power density and lower BOM cost. Finally, the totem pole PFC is inherently capable of bidirectional operation, which is ideal in V2G application and onboard bidirectional battery chargers. The only disadvantage is that with silicon MOSFETs, the totem-pole arrangement allows operating in only discontinuous-conduction mode (DCM) or critical-conduction mode (CrM) because if continuous-conduction mode (CCM) is allowed, the reverse recovery of the MOSFET body diodes can cause excessive losses. The reverse recovery time of the body diode in silicon MOSFETs is much more than that of standard fast-recovery diodes. So the reverse recovery losses will be very high and the efficiency will be low. Although the totem-pole bridgeless-boost PFC is limited in its use with silicon MOSFETs, the advent of silicon carbide (SiC) and gallium nitride (GaN) switching devices with zero-recovery reverse conduction has made it a

preferred choice even in CCM operation. This totem pole PFC can be extended to higher power by interleaving the power stage as [Figure 3-2](#) shows.

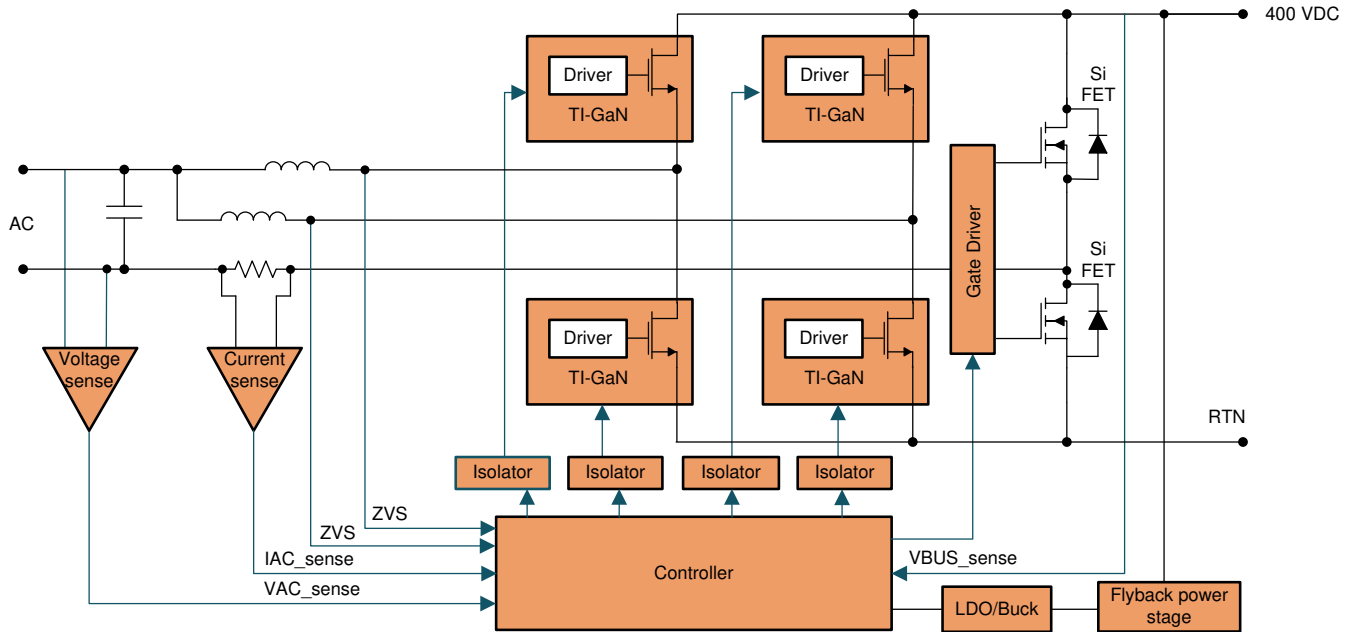

Figure 3-2. Interleaved Totem Pole PFC

The [98.6% Efficiency, 6.6-kW Totem-Pole PFC Reference Design for HEV/EV Onboard Charger](#) and [High efficiency GaN CCM totem pole bridgeless Power Factor Correction \(PFC\)](#) reference designs show applications of interleaved PFCs in electric vehicle charging applications.

3.2 Single-phase Neutral Point Clamped PFC

[Figure 3-3](#) shows a typical neutral point clamped PFC topology in an EV charging station.

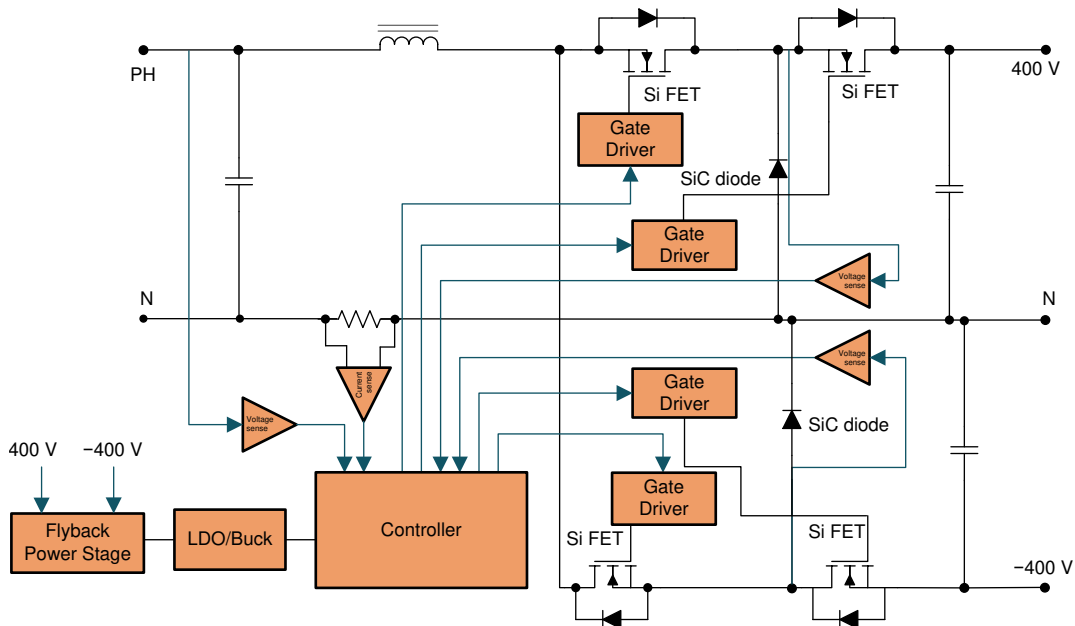

Figure 3-3. Neutral Point Clamped PFC

This topology has several advantages over a conventional two-level converter. First multilevel converters not only can generate the output voltages with very low distortion, but also can reduce the dv/dt stresses with lower voltage across the power switches; therefore, electromagnetic compatibility (EMC) problems can be reduced.

Secondly, multilevel converters can draw input current with low distortion and hence they have better total harmonic distortion performance and require less bulky input inductors. The multilevel feature of this topology enables more cost-effective MOSFETs to be utilized, further reducing the cost of the design. GaN/SiC can be used in this topology when very high efficiency and power density are needed. Finally active switches allow bidirectional operation of the converter. One particular disadvantage is the greater number of power semiconductor switches needed. Although lower voltage rated switches can be utilized in a multilevel converter, each switch requires an isolated gate drive circuit which can be quite costly and challenging to design.

3.3 Three-phase Two-level PFC

Figure 3-4 shows the typical configuration of a two-level three-phase PFC. The six-switch boost-type rectifier features a very simple circuit topology and easy control. It facilitates bidirectional power flow and can achieve a high power factor with reasonable efficiency.

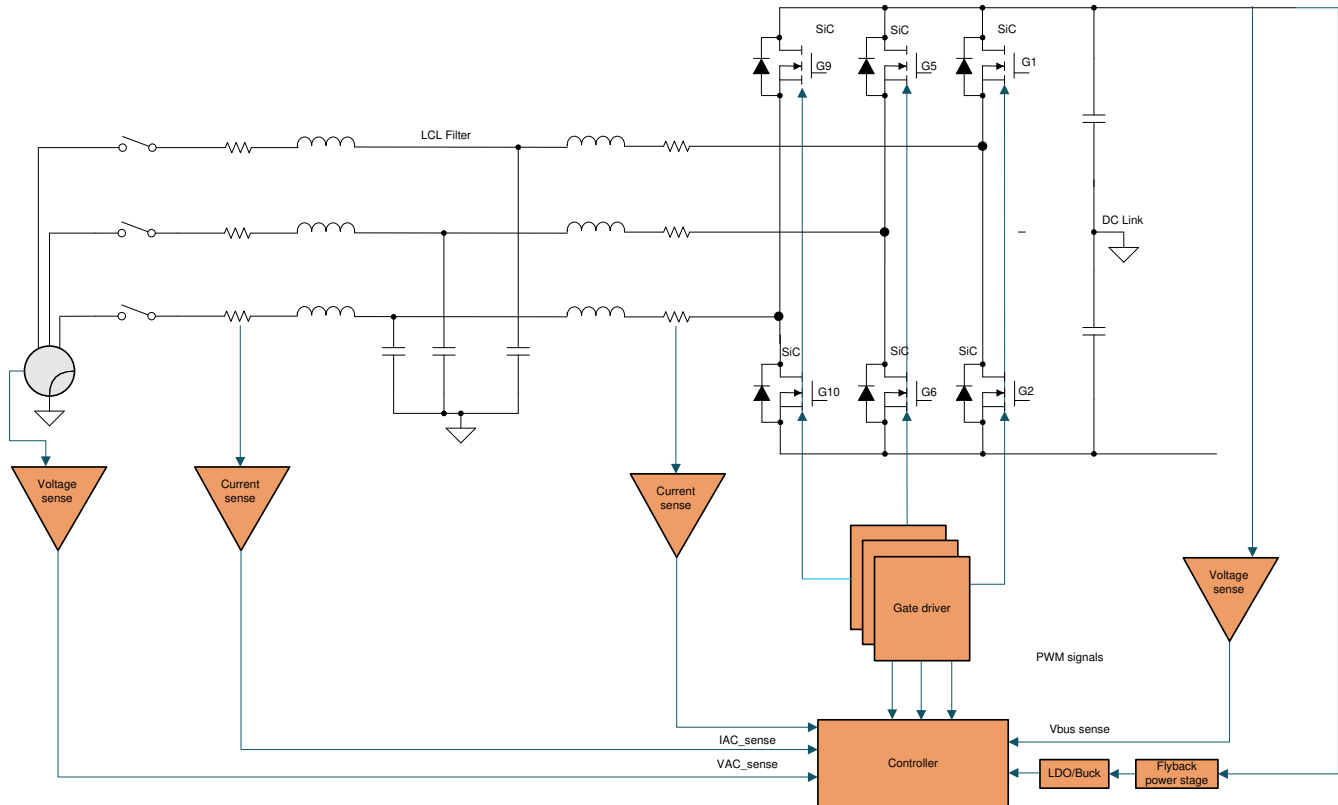

Figure 3-4. Two-level PFC

Since this topology is a two-level topology, it requires high-voltage blocking switches to block the entire DC link voltage. For example, in an 800-V DC link voltage application, a 1200-V rated blocking capacity Silicon Carbide (SiC) is required for the power stage. One of the drawbacks of this topology is the bulky filter inductor which it requires to regulate the input current THD to low values. Hence, the power density is low compared to the other competitive three-level topologies which are documented in Section 3.4, Section 3.5, and Section 3.6. Also, the peak voltage stress on the devices is very high which affects the long-term reliability of the semiconductor and other passive devices used in the power stage. Finally, the electromagnetic interference (EMI) performance of the converter is significantly lower when compared to other popular multilevel PFC topologies.

3.4 Three-phase Vienna PFC

The Vienna rectifier power topology, shown in Figure 3-5, is used in high-power, three-phase power factor correction applications. The Vienna rectifier is popular due to its operation in continuous conduction mode (CCM), inherent multilevel switching (three level), and reduced voltage stress on the power devices. Both hysteresis-based and sine triangle based controllers have been used for Vienna rectifiers, hence it is relatively simpler to control due to the smaller amount of PWMs required for this topology. One of the drawbacks of this topology is that it only supports unidirectional mode power transfer from the grid to the DC side. Vienna Rectifier

is characterized by a relatively small overall volume or a high power density as it requires approximately only half of the inductance for the boost inductors compared to the two level rectifiers discussed in [Section 3.3](#). The multilevel signature of output voltage also provides a better THD performance. Opposed to the two-level PFC, the Vienna Rectifier enables high efficiency at elevated switching frequencies with Si MOSFETs or 600-V to 650-V IGBTs and SiC Schottky diodes as a result of its three-level characteristic and does not require advanced 1200-V SiC power FETs to lower the switching losses. The [Vienna Rectifier-Based Three Phase Power Factor Correction Reference Design Using C2000 MCU](#) TI reference design contains details on the implementation of this converter.

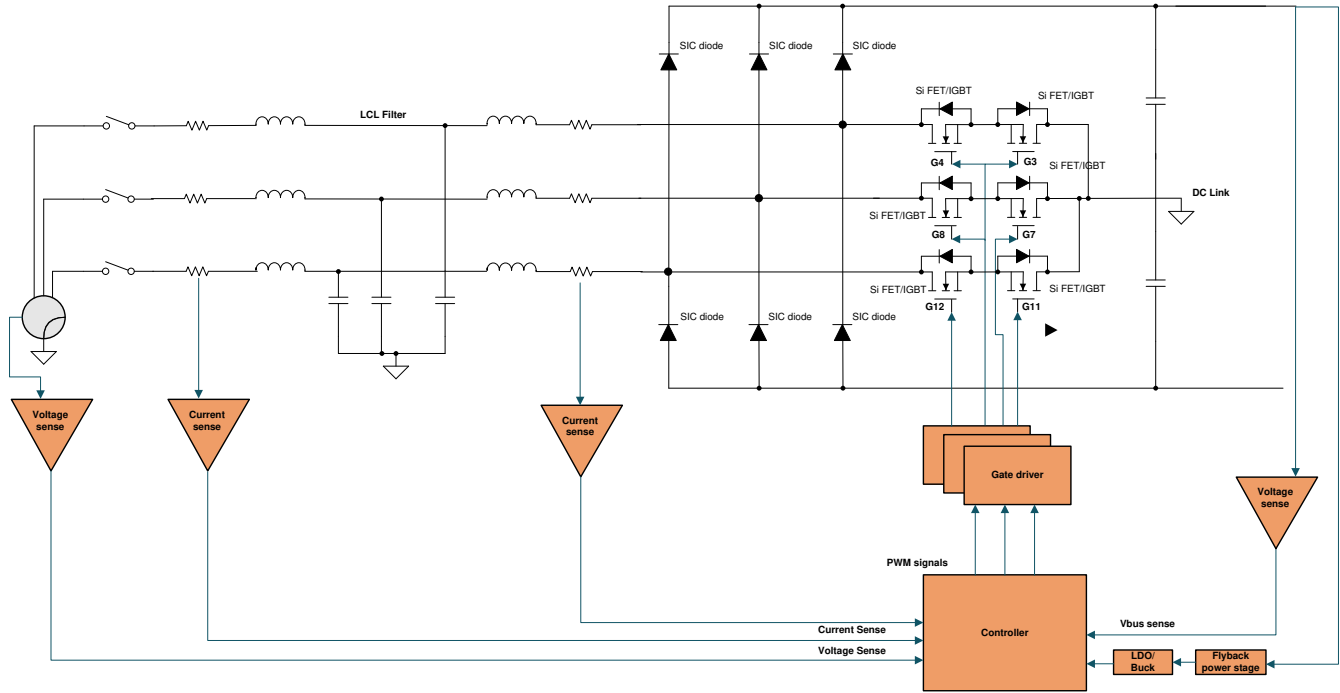

Figure 3-5. Vienna Rectifier

3.5 Three-phase ANPC/NPC Three-level PFC

Figure 3-6 illustrates the basic topology of the *Neutral Point Clamped* converter. This is similar to the single-phase NPC multilevel topology seen before which has been extended to the three phases where all switches of this topology are needed to block only half the bus voltage. Hence the voltage stress on the devices is the lowest among all the topologies discussed so far. Therefore this topology can be easily scaled across multiple platforms for implementation with SiC, GaN, and Si MOSFET depending on the power level, cost, and target efficiency.

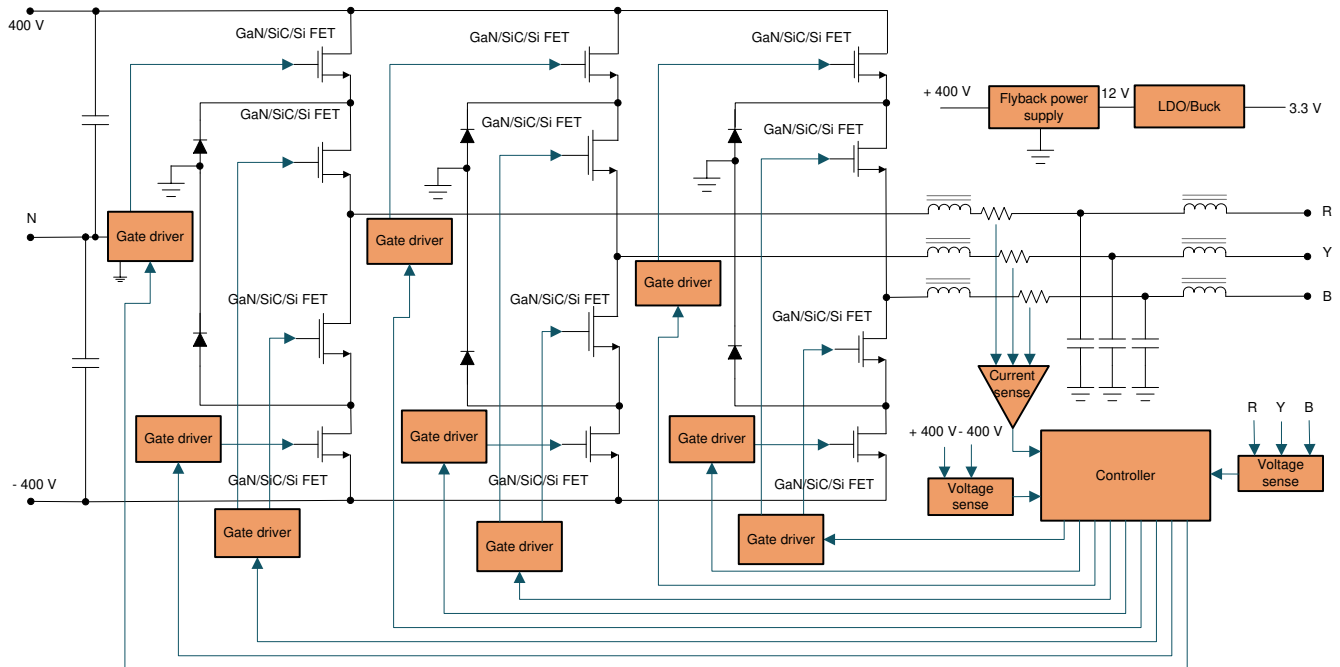

Figure 3-6. Three-phase Three-level NPC

Since only half of the voltage has to be switched and this also cuts the switching losses in the MOSFETs by half, it is possible to use 600-V components instead of 1200-V types. On top of that, in the 600-V technology much faster components are available than in 1200 V. This leads to further reduction of the switching losses. The *Neutral Point Clamped* topology will have lower ripple in the output current and half of the output voltage transient. This will reduce the effort for filtering and isolation in the filter inductor. Hence we can achieve high-power density with less inductance needed to regulate the THD of the current waveform. Multilevel converters not only generate the output voltages with very low disturbance, but also can minimize the dv/dt stresses across devices thereby electromagnetic interference (EMI) issues can be reduced. Moreover, this topology also offers bidirectional transfer of power and is preferred choice for switching frequencies greater than 50 kHz owing to lesser switching losses and greater efficiency.

One particular drawback is the high number of power semiconductor switches needed. Despite the fact that lower voltage rated switches can be utilized in a multilevel converter, each switch needs a linked gate drive circuit and also the control is quite complex with the increased number of devices. As this topology uses both active semiconductor switches and diodes, their unsymmetrical distribution of losses across the power stage and thermal management can be quite challenging. In many situations, to have a more symmetrical loss distribution, the diodes of the NPC topology are replaced with active switches. This gives rise to an Active Neutral Point Clamped (ANPC) converter topology as Figure 3-7 shows. Also with reduced blocking voltage across all switches, Gallium Nitride (GaN) can be used for the high-frequency switches in this topology which improves efficiency and power density of the converter.

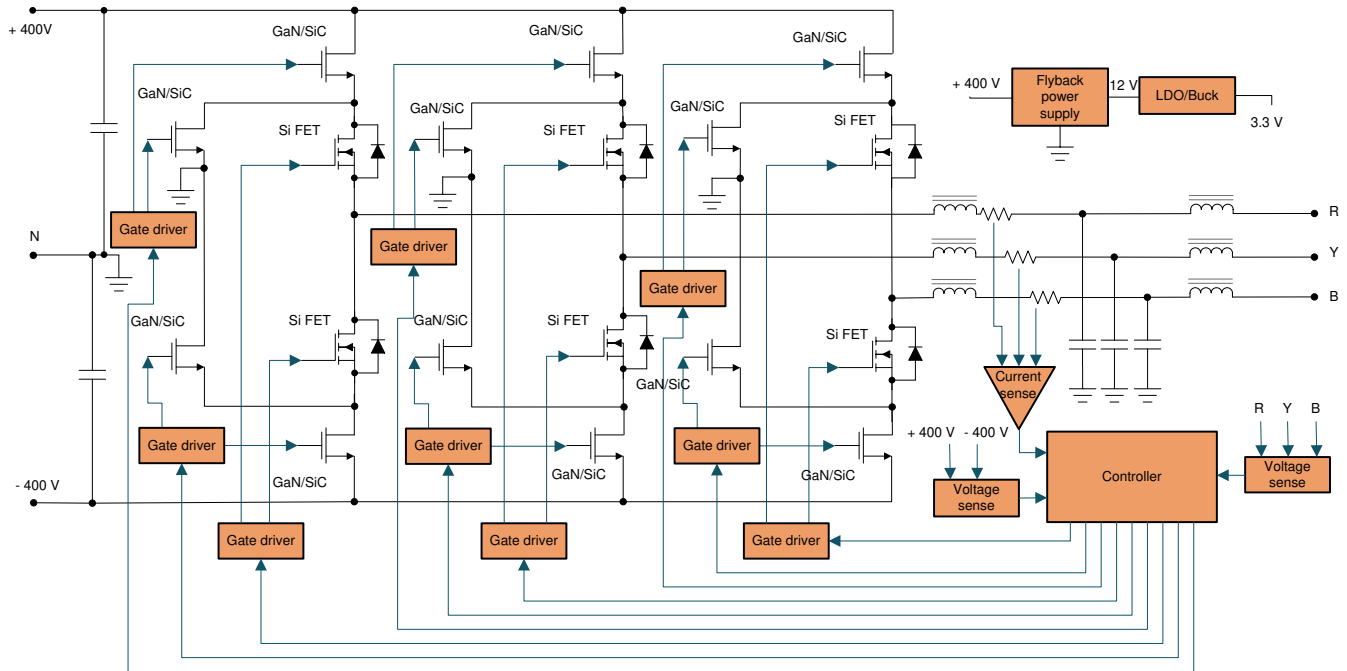

Figure 3-7. Three-phase Three-level ANPC

3.6 Three-phase TNPC Three-level PFC

Figure 3-8 depicts the basic topology of the 3L T-Type converters. The conventional two-level Voltage Source Converter (VSC) topology is extended with an active, bidirectional switch to the DC-link midpoint. For 800-V DC link voltages, the high-side and the low-side on each phase would usually be implemented with 1200-V IGBTs/diodes as the full voltage has to be blocked. Differently, the bidirectional switch to the DC-link midpoint has to block only half of the voltage. It can be implemented with devices having a lower voltage rating like two 600-V IGBTs including antiparallel diodes. Due to the reduced blocking voltage, the middle switch shows very low switching losses and acceptable conduction loss. Contrary to the previously-discussed three-level NPC topology, there is no series connection of devices that has to block the whole DC-link voltage. For the NPC topology, switching transitions directly from the positive (P) to the negative (N) DC-link voltage level and vice versa are usually omitted as there might occur an uneven share of the voltage to be blocked in the transient case when both FETs connected in series turn off at the same time. This undesirable effect cannot occur in the T-type topology. It is not necessary to implement low-level routines which prevent such transitions or ensure a transient voltage balancing among series connected IGBTs. Another additional benefit related to using single 1200-V devices to block the full DC-link voltage is reduced conduction losses. Whenever the output is connected to (P) or (N), the forward voltage drop of only one device occurs, contrary to the NPC topology where always two devices are connected in series. The conduction losses are considerably reduced making the T-type an interesting choice even for low switching frequencies.

Overall, the conduction losses are significantly lower when compared with NPC but the switching losses are high due to the devices which block the full DC link voltage. Due to limited component count when compared to NPC topology and better efficiency, power density and bidirectional operation capability when compared to Vienna Rectifier and two level PFC, the T-type rectifier is best suited for applications upto 50-khz switching frequency beyond which NPC performs better. One of the drawbacks of this topology is the high peak voltage stress across the high voltage blocking FETs. Finally, similar to the other topologies this also has a good THD performance, so it does not require bulky inductor at the input. TI's [Three-level, three-phase SiC AC-to-DC converter reference design](#) contains details on the implementation of this converter.

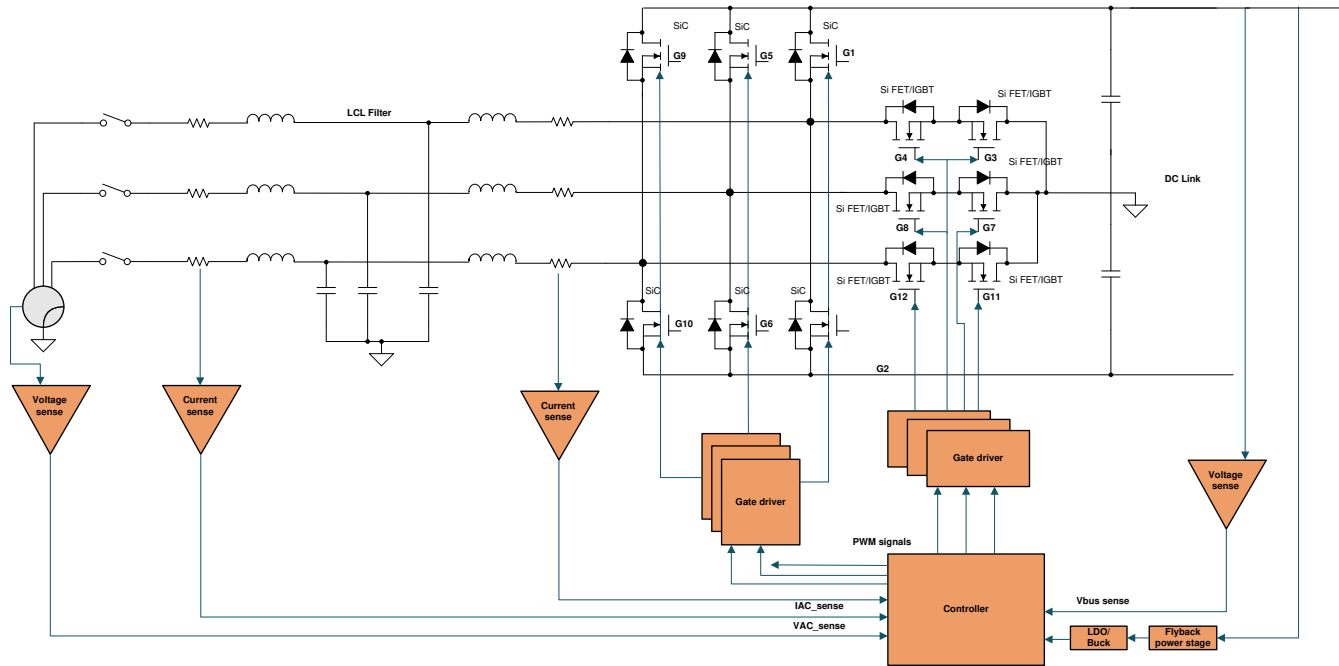

Figure 3-8. Three-phase Three-level T-type PFC

3.7 Summary of AC/DC Topologies

Table 3-1 compares and summarizes the previously-discussed PFC topologies.

Table 3-1. Pros and Cons of PFC Topologies

	2-Level	3-Level NPC	3-Level Vienna	3-Level TNPC	3-Level ANPC
THD of output current	High	Very low	Very low	Very low	Very low
Peak voltage stress on active and passive devices	High	Low	Low	Low / (High Blocking)	Lowest
Power density	Low	Higher	High	High	Higher
Bidirectional	Yes	Yes	No	Yes	Yes
Conduction loss	Low	high	high	Mid	high
Switching loss	High	Low	Mid	Mid	Low
Efficiency	Low	Very High (at high frequency)	High	High	Highest
Cost	Low	High	Mid	Mid	High
Control	Easy	Mid	Mid	Mid	Mild
Input inductor size	Large	Low	Low	Low	Low
Thermal management	Easy	Difficult due to unsymmetrical loss distribution	Mild	Easy	Easy

4 Power Topologies in DC/DC

This section explores four different topologies of high-power DC/DC converters; namely the LLC resonant converter, the Phase-shifted Full Bridge (PSFB), Single-phase Dual-Active Bridge (DAB) and the Dual-Active Bridge in CLLC mode (DAB – CLLC).

4.1 Conventional Phase-shifted Full Bridge (PSFB)

Figure 4-1 shows the basic topology of the phase shifted full bridge converter. The phase shifted full bridge belongs to the family of *Dual Active Bridge* converters where the active switches on the secondary are replaced with diodes. Due to this, it allows only unidirectional power transfer. The [Phase-Shifted Full Bridge DC/DC Power Converter](#) TI reference design contains details on the implementation of this converter.

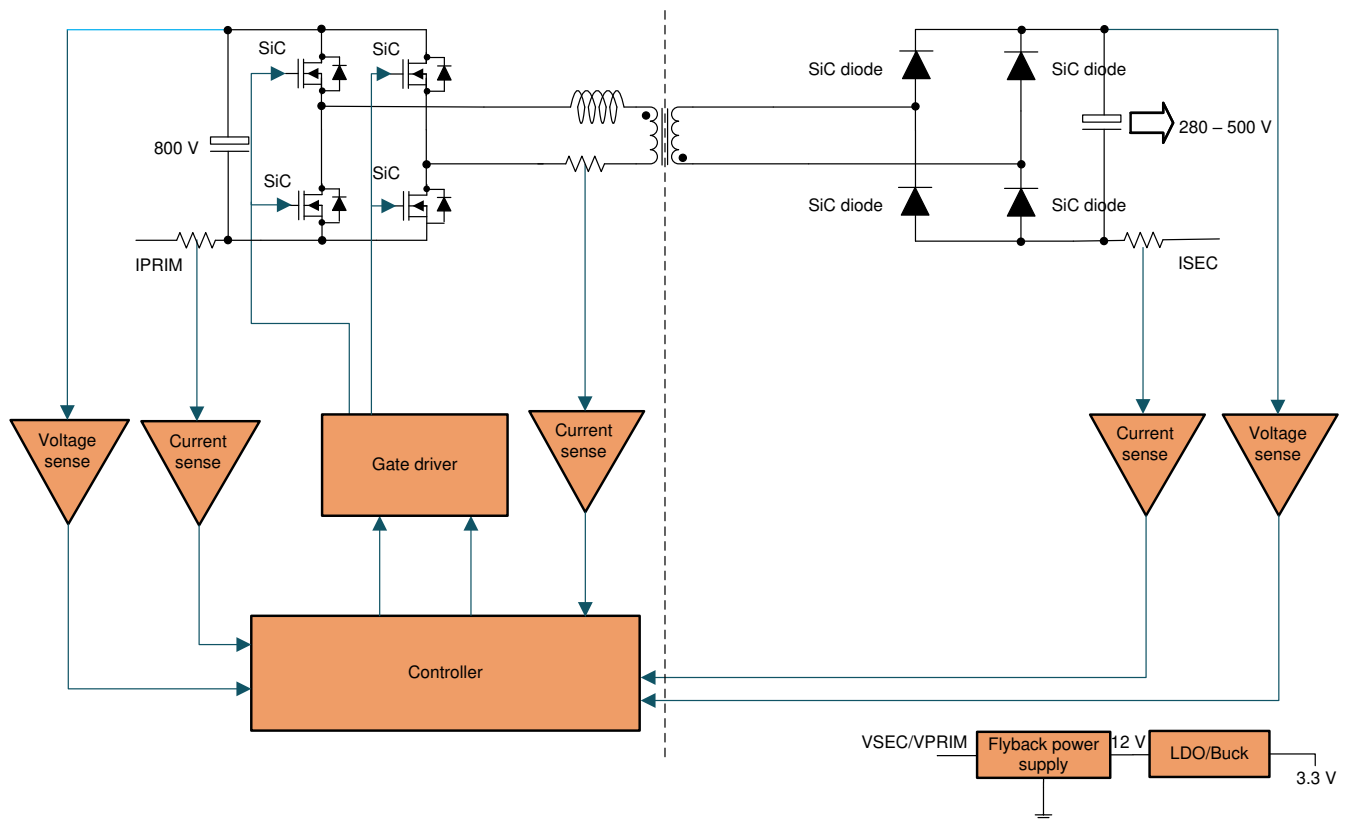

Figure 4-1. Phase-shifted Full Bridge

The power transfer between the primary and secondary is controlled by varying the phase between the switch legs of the primary bridge. As a result it is possible to obtain ZVS turn on of one leg and low voltage turn on of the other leg minimizing losses. The passive diodes on the secondary can experience hard switching and result in more conduction losses which can reduce the efficiency of this converter. This converter suffers non ZVS turn on loss at light load condition and non ZVS turn off. Typically burst mode of operation is used to maintain ZVS at light load condition. This converter is also modular and it can be paralleled to obtain higher power throughput in EV charging stations. In PSFB, dithering can be easily implemented to reduce the conducted EMI signature. This topology requires a DC blocking capacitor which is needed to block DC voltage offset saturating the transformer in voltage mode control. This converter often requires an additional shim inductor which is needed for ZVS operation and it can make the converter bulky and can hamper power density.

4.2 Dual Active Bridge (DAB)

Figure 4-2 depicts the basic topology of the *Dual Active Bridge* converter. It consists of full bridge with active switches on both the primary and secondary sides connected together by a high-frequency transformer. Because of the inherent lagging current in one of the bridges, the current discharges the output capacitance of switches of one bridge (say secondary side) and some switches of the primary side thereby enabling ZVS turn on. In addition to this lossless capacitive snubbers can be used across the switches to reduce turn off losses. The main advantages of this converter are its inherent bidirectional capability which is achieved by controlling the phase angle between the two bridges and its modularity that allows for it to be scaled to higher power levels.

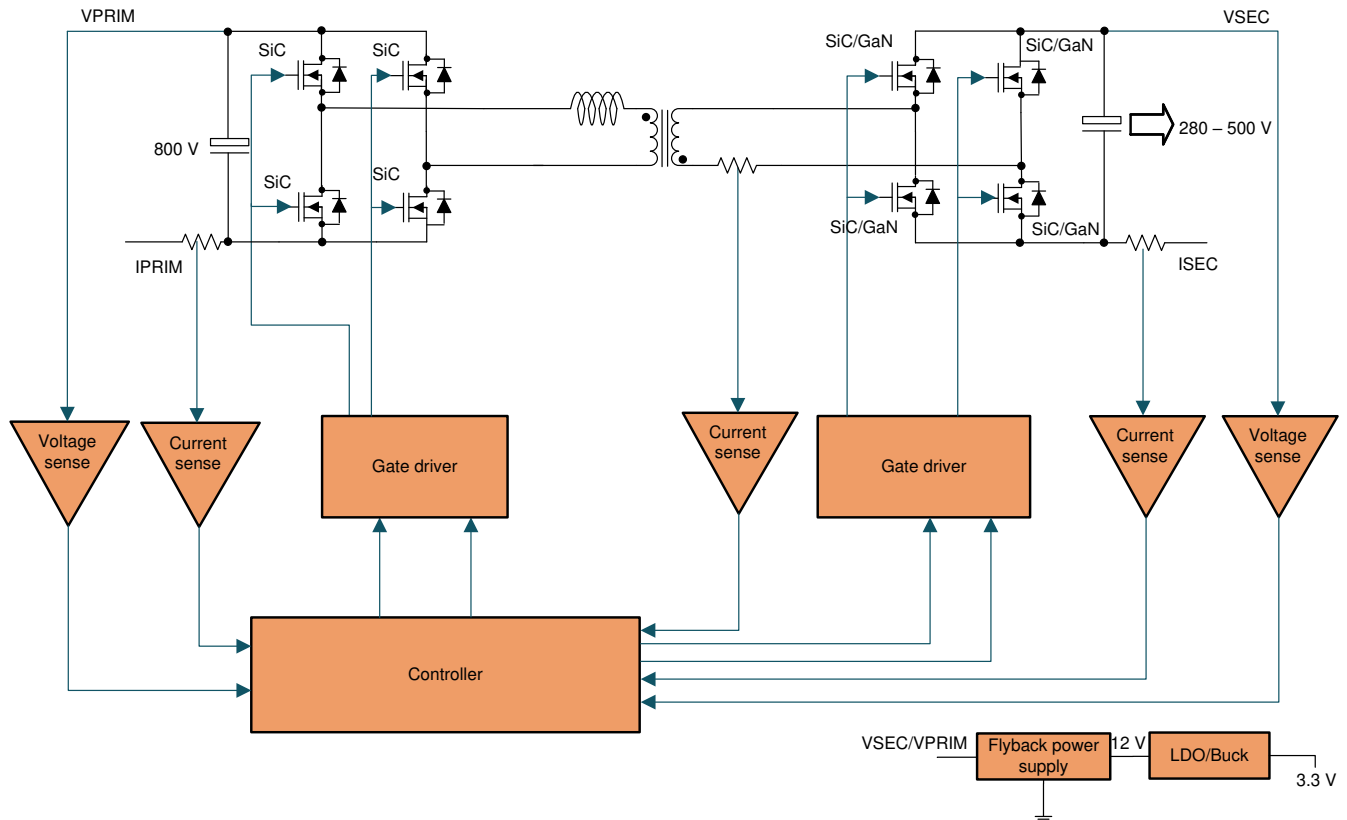

Figure 4-2. Dual Active Bridge

The control of the DAB ranges from simple (or single phase shift modulation) to complex (for extended, dual and triple phase shift modulation). This topology can be used to cover a wide variation of battery voltages with single phase shift modulation but circulating currents in the transformer increase which drastically reduces efficiency. But with advanced modulation schemes like triple phase shift, the converter can theoretically achieve ZVS over the entire operating range. The utilization of the output power to the transformer KVA rating is high for this topology. The required output capacitor to handle the ripple currents is also low for this converter. This converter with the relatively fewer number of devices, soft-switching commutations, low cost, and high efficiency is used in applications where the power density, cost, weight, isolation, and reliability are critical factors. Another limiting feature is that the converter often requires an additional shim inductor which is needed for ZVS operation and it can make the converter bulky and can hamper power density. The [Bi-directional, dual active bridge reference design for level 3 electric vehicle charging stations](#) TI reference design contains details on the implementation of this converter.

4.3 LLC Resonant Converter

The gain of this converter is a function of switching bridge gain, resonant tank gain and transformer turns ratio. The output voltage regulation is achieved by varying the switching frequency of operation. There are three modes/regions of operation in the LLC resonant converter namely the operation at resonant frequency, above resonant frequency and below resonant frequency. During below resonant frequency operation, the resonant half cycle inductor current reaches the value of magnetizing current within the switching cycle and leads to soft switching across secondary rectifier diodes but on the other hand leads to more conduction losses due to more circulating energy. Above resonant frequency operation, leads to increased switching losses and hard commutation of secondary rectifier diodes, but leads to lower conduction losses due to reduced circulating energy. Hence the best performance of these converters is obtained when operated close to resonance frequency where ZVS turn on and ZCS turn off is possible. This converter provides unidirectional power flow and is generally used in applications less than 5 kW. Figure 4-3 shows the topology of the LLC resonant converter.

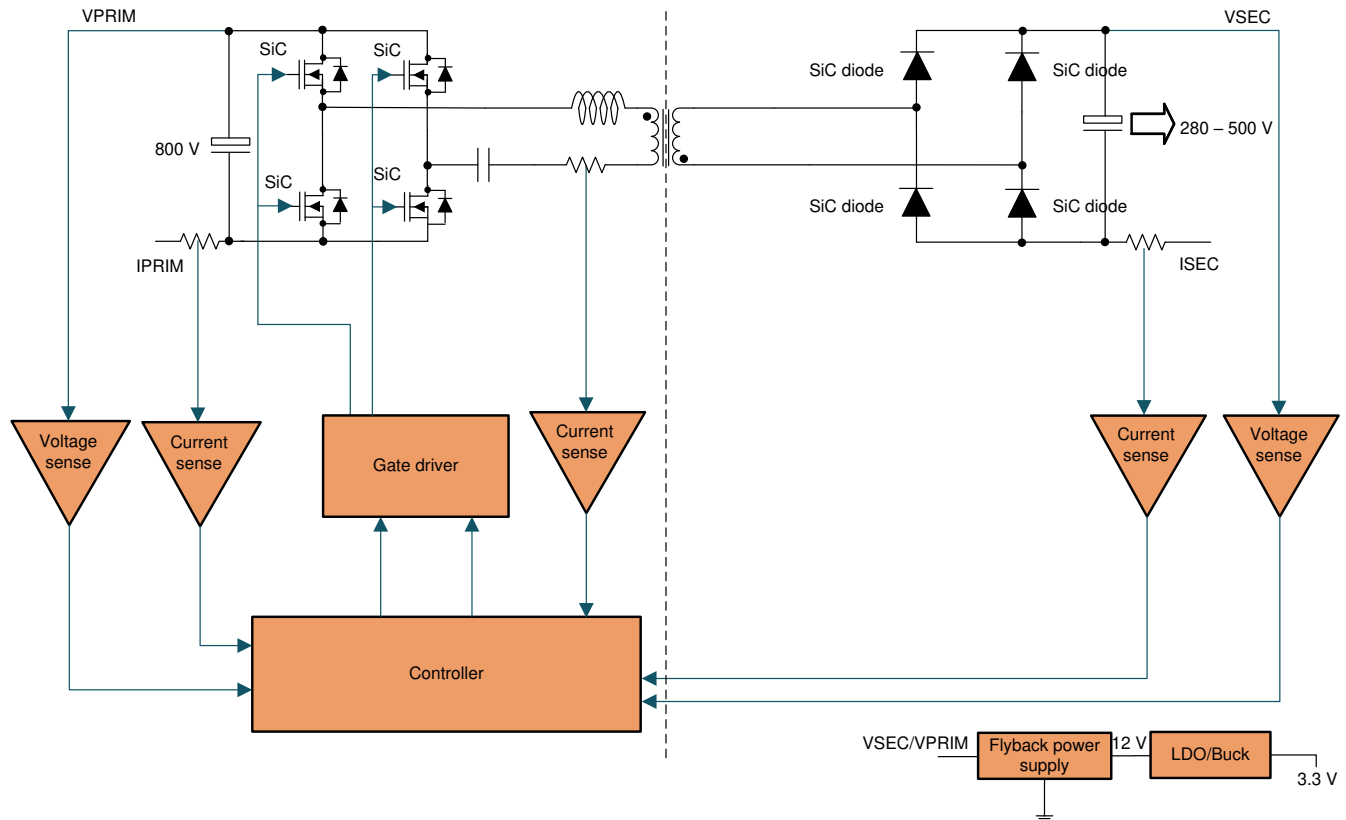

Figure 4-3. LLC Converter

Paralleling and synchronization of multiple LLC converter modules to increase the power throughput is difficult and often requires external control logic for safe implementation. Low di/dt in high-output-voltage designs (greater than 400 V) makes implementation of synchronous rectification in LLC converter quite tricky. The ripple current and peak voltage stress across the active and passive devices is significantly high, hence higher output capacitance is needed for handling high ripple. Also the transformer of LLC converter is also slightly higher in size, hence these passive components significantly reduce the power density of converter. Since this converter soft switches during turn on and turn off, the EMI performance is better when compared to other hard switched topologies previously discussed. The [Two Phase Interleaved LLC Resonant Converter Reference Design Using C2000™ MCUs](#) TI reference design contains details on the implementation of this converter.

4.4 DAB in CLLLC Mode

The CLLC incorporates all the functionalities of the LLC described before, but a major advantage of this topology is that with the use of active switches across the secondary, we can obtain bidirectional power transfer as Figure 4-4 shows. The ZVS/ZCS operation of this converter results in increased efficiency. When there is room to vary the bus voltage by a margin of 10%, this converter can cater to wide varying battery voltage with good efficiency performance, but with a fixed bus voltage this has a very limited range of operation. With capacitors in the primary and secondary side of the transformer, the problem of saturation of the core of the transformer is prevented.

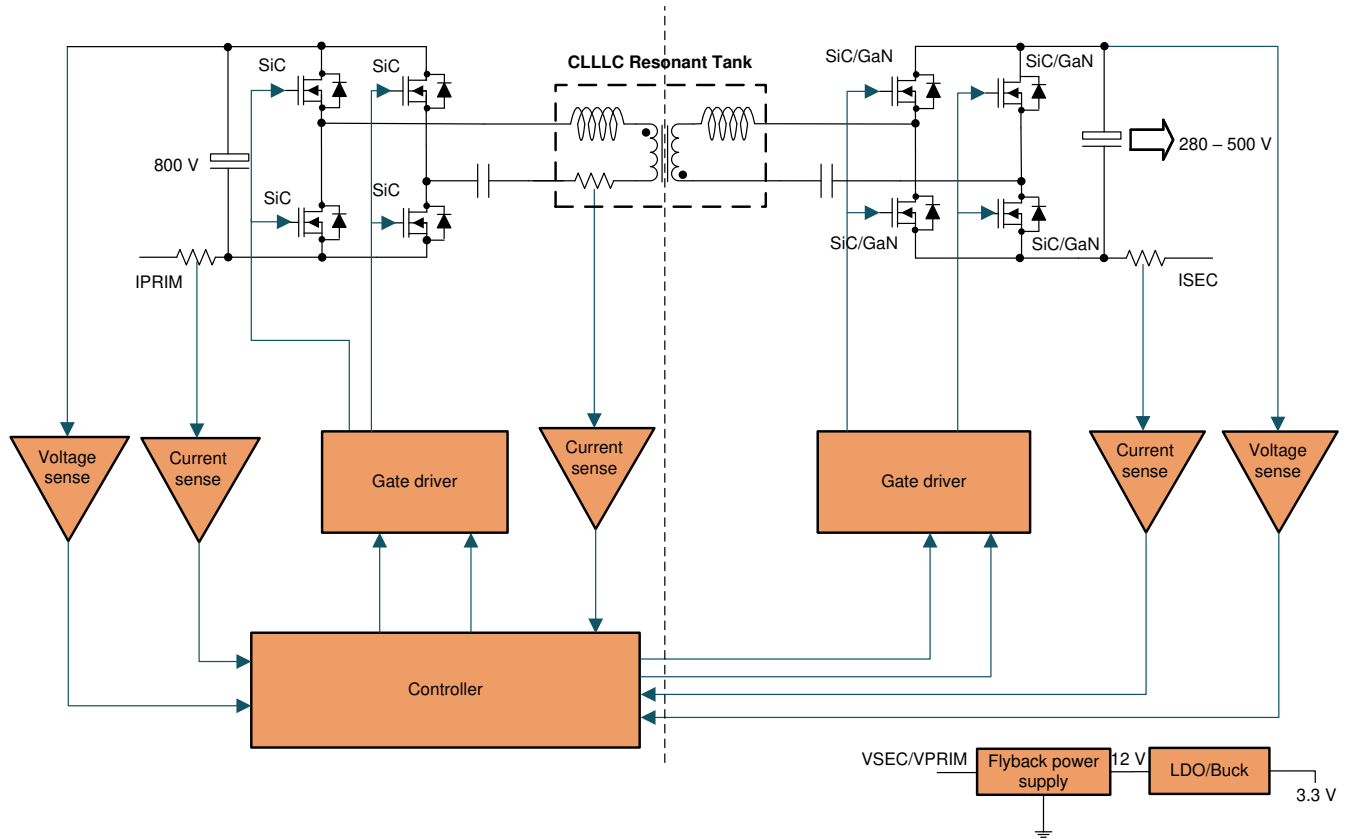

Figure 4-4. DAB- CLLLC Converter

This converter is primarily suited for onboard charger applications but can be used at higher power levels upto 10 kW. But scaling to higher power levels and paralleling can be difficult as it requires a highly symmetrical tank structure and synchronization of multiple modules which can be quite difficult. The [Bidirectional CLLLC resonant dual active bridge \(DAB\) reference design for HEV/EV onboard charger](#) TI reference design contains details on the implementation of this converter.

4.5 Summary of DC/DC Topologies

Table 4-1 compares and summarizes the previously-discussed DC/DC topologies.

Table 4-1. Pros and Cons of DC/DC Topologies

	LLC Converter	Phase-shifted Full Bridge (PSFB)	Dual Active Bridge (DAB)	DAB in CLLC Mode
Peak device stress on primary and secondary side	High	Mild low	Lowest	High
Transformer KVA rating	High	Medium	Low	High
Power output to transformer KVA rating	Low	Medium	High	Medium
Input and output capacitor RMS currents	High	Medium	Low	High
Operation	Unidirectional	Unidirectional	Bidirectional	Bidirectional
Conduction losses	High	Medium	Lowest	Medium
Turn ON switching loss	ZVS	ZVS	ZVS	ZVS
Turn OFF switching loss	Low (ZCS)	High	High (device turn off at peak leakage inductor current value)	Low (primary side turn off decided by magnetizing inductor current, secondary side turn off is zero due to ZCS)
Total losses	Low	Higher	Medium	Low
Control complexity	Moderate	Very simple	Simple to complex	Moderate
Wide Battery Voltage, Fixed Bus Voltage	No, needs additional DC/DC stage	Yes (with reduced efficiency)	Yes (with reduced efficiency)	Limited range
Paralleling Modules	Intensive	Easy	Easy	Intensive
Switching Frequency	Fixed/ High (Si / SiC)	High	High	Very High

5 Upcoming Trends in DC Fast Charging Infrastructure

The state-of-the-art power conversion topologies previously discussed, are driving the need for bidirectional, high-power density, and scalable converters. These are driving the industry toward the latest trends in EV charging which are the concepts of portable chargers and Vehicle to Grid (V2G) technology. This section covers these advances.

5.1 Portable Chargers

Few Automotive OEMs are exploring the possibility of how ubiquitous DC chargers can lead to elimination of EV onboard chargers (OBC) in the years to come, making EVs more efficient and affordable. By pairing a portable (small form factor) DC charger with every EV, auto OEMs could be looking to eliminate OBC from EVs. Eliminating OBC from the car has numerous benefits such as:

- Reduced overall system cost, since Q100 qualified devices/system may not be required
- Serviceability of EV chargers becomes easier, no more downtime for your EV due to a charger breakdown
- Higher efficiency, that is, more miles per charge due to reduced gross vehicle weight
- Most importantly, the rate of charge will no longer be limited by the power rating of the OBC (which is the case while using a L1 or L2 AC charger)

These chargers are expected to be portable, that is, hand-held with a small form factor, natural convection based cooling (i.e. without fans). This may require manufactures to look at GaN/SiC based architecture that can switch in the order for 100s of kHz to a few MHz so as to reduce the size of the entire charger along with low thermal emissions. [Figure 5-1](#) illustrates the block diagram of a portable EV charger.

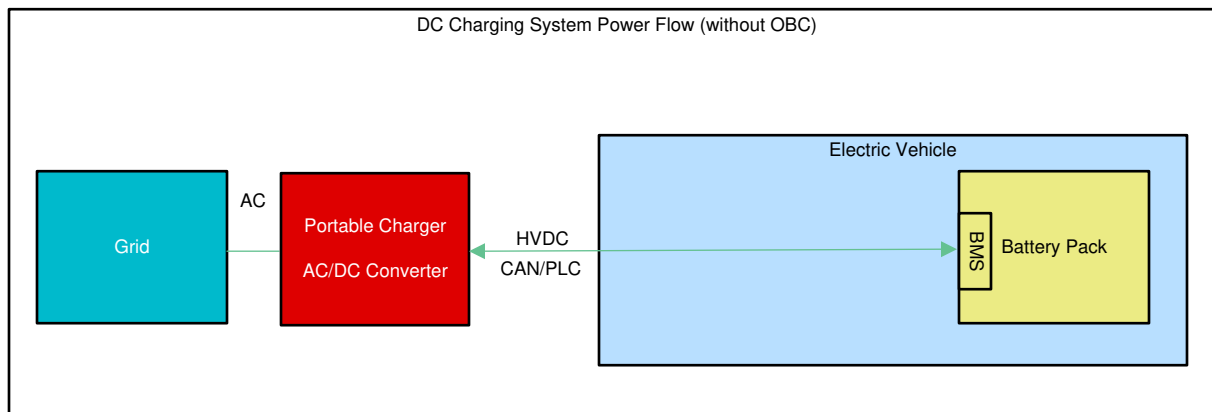

Figure 5-1. Portable EV Charger

5.2 Vehicle-to-Grid Technology (V2G)

'Vehicle to grid' technology, also referred to as V2G enables energy stored in electric vehicles to be fed back into the national electricity network (or 'grid') to help supply energy at times of peak demand. Over 90% of cars are parked at any given time, which is a lot of energy just sitting inside but doing nothing. This energy can be used for *balancing the grid* so that there is enough electricity on the network when we all need it. This necessitates the need for having bidirectional converters in EV charging stations. Figure 5-2 shows an electric vehicle connected to a charging station where bidirectional converters inside the charging station enable the energy stored in the battery to be used for stabilizing the intermittencies in grid.

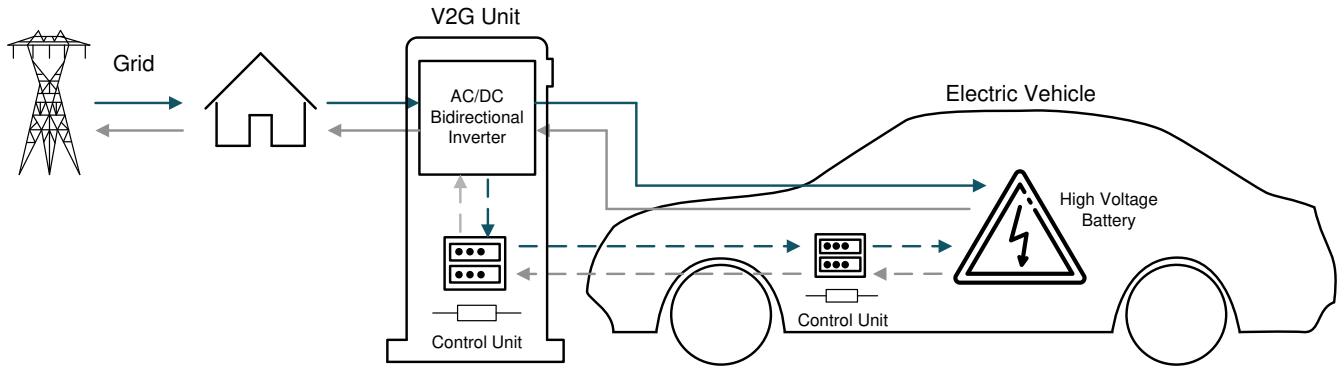

Figure 5-2. V2G Technology

6 Conclusion

The ultimate choice of a power topology boils down to the intended use case of that specific EV Charger namely the targeted power levels, efficiency & power density targets to name a few. While high power highway chargers (or fleet chargers) would look at complex multilevel three-phase PFC and DC-DC stage to pack more-and-more power into them, the new emerging portable chargers could be addressed by a simple interleaved totem pole PFC stage followed by a LLC DC/DC stage. With interest in new requirements like V2G, engineers may have to limit their topology choices to those that support bi-directional power transfer between the Vehicle and the Grid.

No matter, your choice of use case the advancement in the field of power electronics in tandem with semiconductor technology is ready to offer everything you need to build your next generation DC Fast EV Charging Station.

7 References

- [Vienna Rectifier-Based Three Phase Power Factor Correction Reference Design Using C2000 MCU](#)
- [10-kW, Three-Level, Three-Phase T-Type Inverter Reference Design for Solar String Inverters](#)
- [98.6% Efficiency, 6.6-kW Totem-Pole PFC Reference Design for HEV/EV Onboard Charger](#)
- [High efficiency GaN CCM totem pole bridgeless Power Factor Correction \(PFC\) reference design](#)
- Design and Implementation of a Highly Efficient Three-Level T-Type Converter for Low-Voltage Applications, M. Schweizer, J. W. Kolar, IEEE Transactions on Power Electronics, Vol. 28, No. s2, pp. 899-907, February 2013
- [Bidirectional CLLLC resonant dual active bridge \(DAB\) reference design for HEV/EV onboard charger](#)
- [Dual active bridge reference design for level 3 electric vehicle charging stations](#)
- [Phase-Shifted Full Bridge DC/DC Power Converter](#)
- [Two Phase Interleaved LLC Resonant Converter Reference Design Using C2000™ MCUs](#)
- R.W. A. A. De Doncker, D. M. Divan, and M. H. Kheraluwala, "A three-phase soft-switched high-power-density dc/dc converter for high-power applications," IEEE Trans. Ind. Appl., vol. 27, no. 1, pp. 63–73, Jan./Feb. 1991.
- M. H. Kheraluwala, R. W. Gascoigne, D. M. Divan, and E. D. Baumann, "Performance characterization of a high-power dual active bridge dc-to dc converter," IEEE Trans. Ind. Appl., vol. 28, no. 6, pp. 1294–1301, Nov./Dec. 1992.
- A.K. Jain and R. Ayyanar, "PWM Control of Dual Active Bridge: Comprehensive Analysis and Experimental Verification," IEEE Trans. Power Electron., vol. 26, no. 4, pp. 1215-1227, April 2011.
- Overview of Dual-Active-Bridge Isolated Bidirectional DC–DC Converter for High-Frequency-Link Power-Conversion System Biao Zhao, Student Member, IEEE, Qiang Song, Member, IEEE, Wenhua Liu, Member, IEEE, and Yandong Sun

IMPORTANT NOTICE AND DISCLAIMER

TI PROVIDES TECHNICAL AND RELIABILITY DATA (INCLUDING DATASHEETS), DESIGN RESOURCES (INCLUDING REFERENCE DESIGNS), APPLICATION OR OTHER DESIGN ADVICE, WEB TOOLS, SAFETY INFORMATION, AND OTHER RESOURCES "AS IS" AND WITH ALL FAULTS, AND DISCLAIMS ALL WARRANTIES, EXPRESS AND IMPLIED, INCLUDING WITHOUT LIMITATION ANY IMPLIED WARRANTIES OF MERCHANTABILITY, FITNESS FOR A PARTICULAR PURPOSE OR NON-INFRINGEMENT OF THIRD PARTY INTELLECTUAL PROPERTY RIGHTS.

These resources are intended for skilled developers designing with TI products. You are solely responsible for (1) selecting the appropriate TI products for your application, (2) designing, validating and testing your application, and (3) ensuring your application meets applicable standards, and any other safety, security, or other requirements. These resources are subject to change without notice. TI grants you permission to use these resources only for development of an application that uses the TI products described in the resource. Other reproduction and display of these resources is prohibited. No license is granted to any other TI intellectual property right or to any third party intellectual property right. TI disclaims responsibility for, and you will fully indemnify TI and its representatives against, any claims, damages, costs, losses, and liabilities arising out of your use of these resources.

TI's products are provided subject to TI's Terms of Sale (www.ti.com/legal/termsofsale.html) or other applicable terms available either on ti.com or provided in conjunction with such TI products. TI's provision of these resources does not expand or otherwise alter TI's applicable warranties or warranty disclaimers for TI products.

Mailing Address: Texas Instruments, Post Office Box 655303, Dallas, Texas 75265
Copyright © 2020, Texas Instruments Incorporated